

*Sustainable logistics  
with intelligent docking systems*



# Loading Technology

Complete solutions for more efficiency





# The right concepts

## Efficient planning

### Energy efficiency

Thermographic studies confirm that a building's openings are a particularly critical factor when it comes to energy efficiency. With proper planning and the proper equipment that matches the building's intended function, thermal loss can be kept at a minimum.

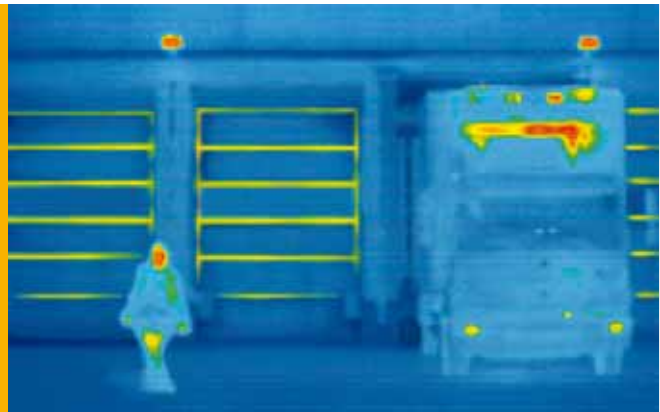

### Safety

Workplace safety is quite rightfully a very important issue. Accident and health risks as well as damage to goods, vehicles and building equipment must be avoided. Especially at loading bays, where your own employees and external staff work together, suitable measures must be considered carefully.



### Longevity

The rough nature of daily use quickly leaves its mark on loading bays – quick wear and tear, collision damage and planning errors can require costly repairs and replacements within a very short period of time. High-quality materials, coupled with foresighted planning and the selection of suitable protection measures protect your valuable investment.



Increasing demands as to energy efficiency, safety and longevity require individually adjusted solutions. We advise you on site and recommend an economically efficient system which in terms of quality, function and reliability meets your requirements.

# The right products

Developed and manufactured in-house

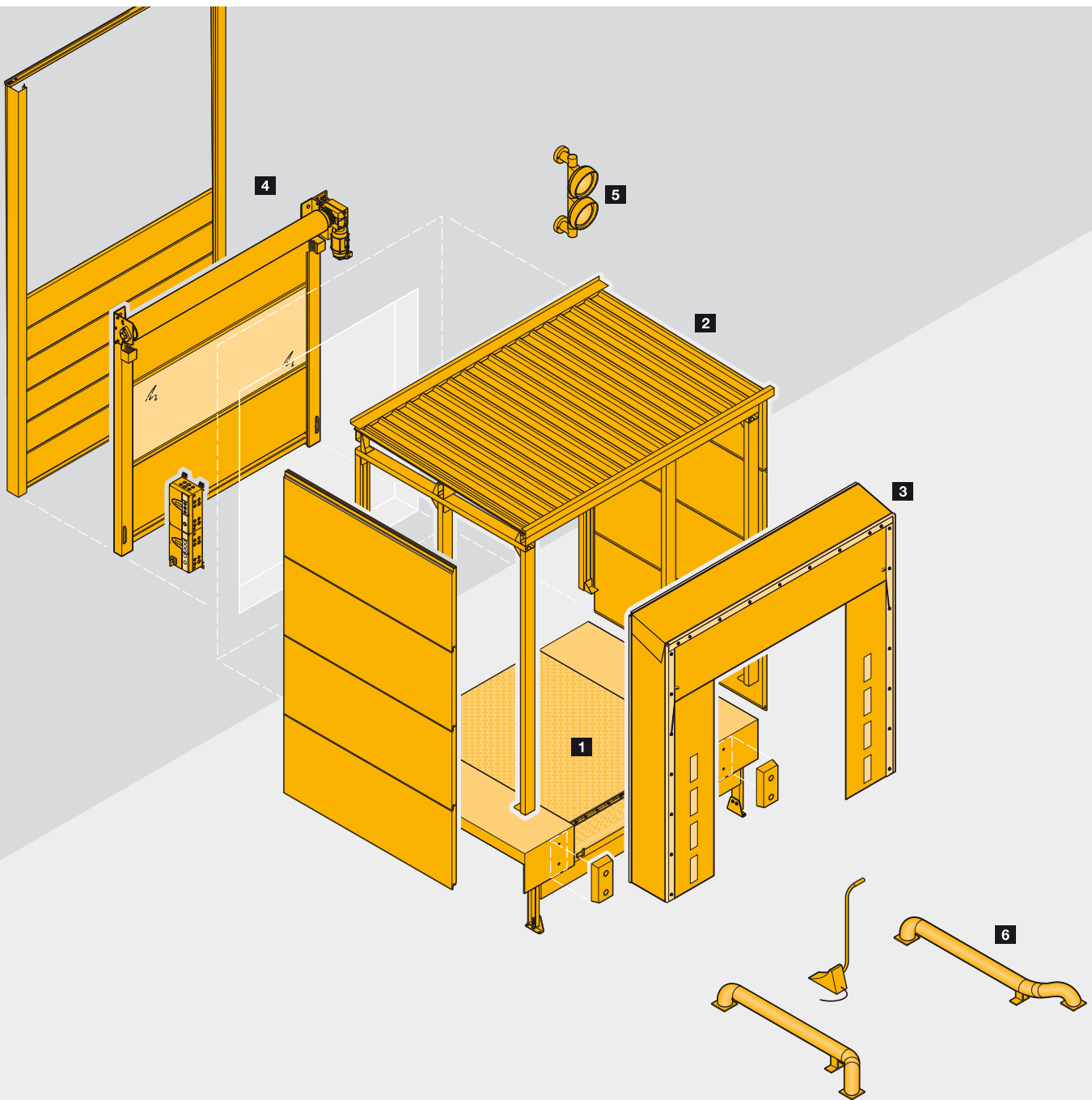

## Optimally co-ordinated system

All components for your loading bay are available from a single source: Hörmann. Developed and manufactured in-house, Hörmann products are optimally co-ordinated, which ensures smooth loading and unloading at your loading bay.

- 1 Dock levellers**
- 2 Loading houses**
- 3 Dock seals / shelters**
- 4 Industrial doors**
- 5 Control systems**
- 6 Dock and safety accessories**

# Good reasons to try Hörmann

Individual solutions from the market leader for doors and loading technology



# 1

## Robust dock levellers

Sustainability and quality go hand in hand. Dock levellers have to withstand the rough day-to-day loading environment. For this reason, all components are manufactured using high-quality materials. The design of all dock levellers corresponds to EN 1398 and, with regard to loading capacity, is dimensioned generously. Particularly sturdy flat anchors, ventilation slots in the edge bracket and adjustment angles to screw ensure reliable fixing in the building structure, one of the most important prerequisites for a long service life.

For further information, see pages 18 – 19.



# 2

## Energy-efficient loading houses

The dock leveller is fit directly in front of the building with a loading house, allowing the building opening to be sealed efficiently with an industrial door. As early as the quotation phase, we are able to provide model statistics defining the maximum wind and snow loads for Hörmann loading houses.

Any unevenness in the door can easily be compensated for using adjustable feet.

For further information, see pages 34 – 37.



# 3

## Flexible dock seals and shelters

Dock seals and shelters are particularly efficient when they are optimally adapted to the docking vehicles and the loading situation. This requires a wide range of flexible solutions.

Robust push-in flap dock shelters with different frame constructions prevent them from being damaged during docking.

Inflatable dock seals adjust to different vehicle dimensions. Roll-up flaps compensate for even larger differences in vehicle heights.

Dock seals and shelters with telescopic link arms or rising roof constructions are recommended to compensate for vehicle movements or when placing interchangeable containers.

For further information, see pages 38 – 43.



# 4

## Compatible control systems

From development to production, all Hörmann door and dock leveller controls come from the same source, making them optimally matched to each other. As a result, you benefit from a uniform operating concept with standardised housing sizes and the same cable sets for dock levellers and door controls.

Another advantage: If the dock leveller control is placed beneath the door control, both controls can be combined into a single compact unit.

For further information, see pages 26 – 27.

# Proper planning

## Sustainability begins with planning

### Loading technology inside the building

With many interior solutions, energy is lost through the dock leveller even when the door is closed. This leads to unnecessary energy loss in temperature controlled buildings, which can be prevented with the proper planning.

For such cases, Hörmann offers concepts with advance travel doors and insulated panels under the dock leveller. This minimises heat loss outside loading times.

For buildings that are not temperature controlled, the conventional fitting with a door mounted to the dock leveller is suitable.



### Loading technology in front of the building

In the external solution, the dock leveller is placed in front of the building in a loading house. The loading house acts as the door to the building, minimising energy loss, especially when no loading is in process.

A further advantage: The interior building space can be used entirely up to the door. This solution is also suited for modernisation, as a complete loading bay can be added to the building without costly reconstruction measures.





## Planning made simple with Hörmann

Hörmann offers detailed **planning documents** as well as descriptive **information and demonstrations** of special solutions on the Internet. Utilise the know-how of Hörmann to optimise your planning!



**Planning documents** with detailed information and drawings



**Information and demonstrations** of special solutions such as the DOBO system



You can find information and demonstrations at

[www.hoermann.com/en/videos](http://www.hoermann.com/en/videos)



# Logistics solutions inside the building

## Example plans

### Fleet with nearly equal loading heights

Mechanical dock levellers are economic solutions whenever lorries with nearly identical loading heights are loaded and unloaded and no under-riding is required. In case of relatively low loading frequencies, we recommend using a manual rolling shutter as the hallway door.

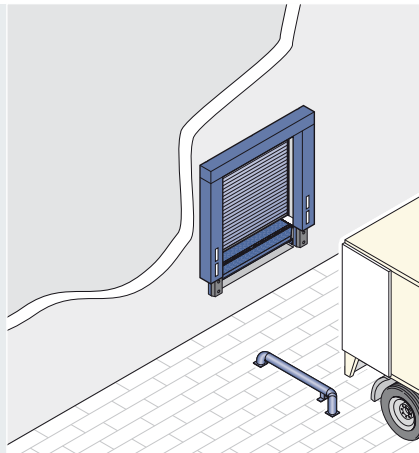

#### Recommended product

- Mechanical dock leveller MLS
- Manual rolling shutter
- Dock shelter
- Buffers
- Wheel guide

### Lorries with different loading heights

If a loading bay is used by lorries with different loading heights, a solution with a hydraulic dock leveller is the best choice. A lorry tail lift can be moved underneath the dock leveller. With suitable dimensions, it can also be used for the loading of heavy goods.

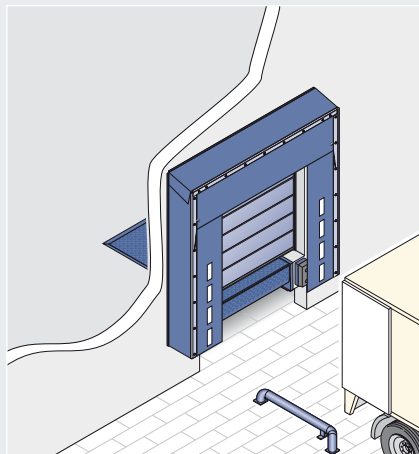

#### Recommended product

- Hydraulic dock leveller
- Industrial rolling shutter or sectional door
- Dock shelter
- Buffers
- Wheel guide

### Thermal insulation solution for temperature controlled buildings

Most of the time, goods are not being loaded at a loading bay and the door is closed. To minimise thermal losses during those periods, a double-skinned thermally insulated sectional door is positioned in front of the dock leveller and the dock leveller is additionally insulated on the underside by an insulated panel.

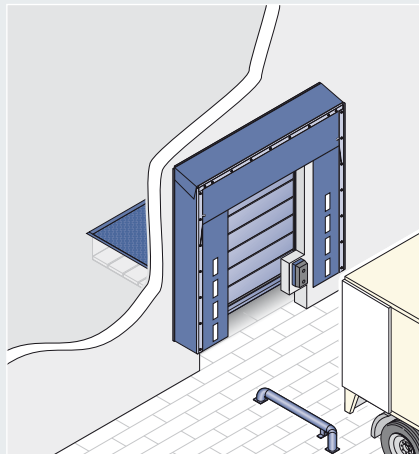

#### Recommended product

- Hydraulic telescopic lip dock leveller with extended lip
- Insulated dock leveller bottom side with insulated panel
- Industrial sectional door travelling in front of the dock leveller with a low U value
- Dock shelter
- Buffers
- Wheel guide

### DOBO system for refrigerated warehouses

To prevent any interruptions of the cold chain of refrigerated or frozen goods, the lorry doors are only opened after docking. The optimally co-ordinated Hörmann DOBO system offers a high degree of comfort and low energy loss. See page 24 for detailed information.

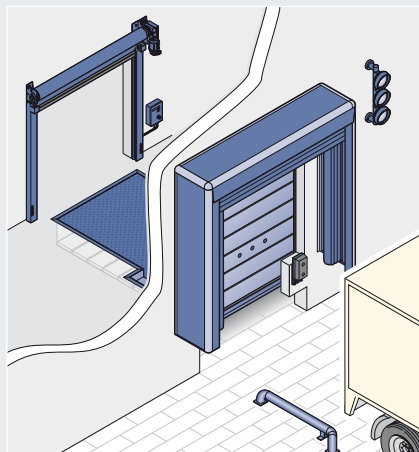

#### Recommended product

- Hydraulic telescopic lip dock leveller as DOBO version with extended lip
- Graduated ramp
- Insulated dock leveller bottom side with insulated panel
- Industrial sectional door travelling in front of the dock leveller with a low U value
- Flexible high-speed door
- Inflatable dock seal
- Height-adjustable buffer
- Docking assistant HDA-Pro
- Wheel guide

# Logistics solutions in front of the building

## Example plans

### Temperature controlled building and lorry with the same loading height

In this energy-efficient and inexpensive solution, the door travels down to the building floor and seals the door opening. The mechanical dock leveller is fitted in front of the building and bridges the difference to the lorry loading surface in case of small height differences.

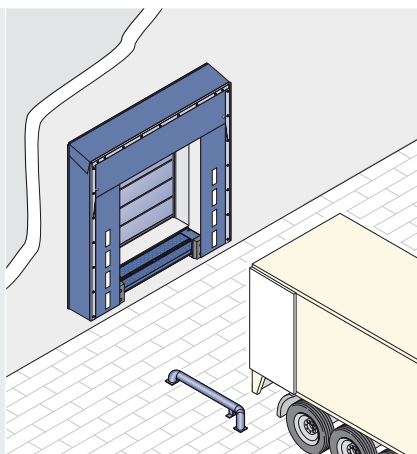

#### Recommended product

- Mechanical dock leveller MRS
- Industrial door with low U-value
- Flap dock shelter with 900 mm depth
- Buffers
- Wheel guide

### Temperature controlled building with fully utilised space

By moving the dock leveller in front of the building, the building can be completely utilised. The hydraulic dock leveller allows docking of lorries with different loading heights. In addition, the double-skinned insulated industrial door seals the building well.

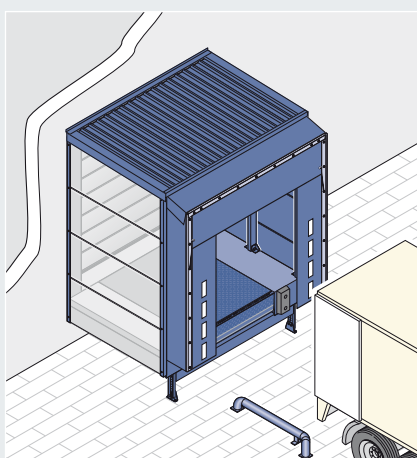

#### Recommended product

- Loading house with hydraulic dock leveller
- Industrial sectional door with low U-value as the door to the building
- Dock shelter
- Buffers
- Wheel guide

### DOBO system for safe loading

For customs goods and to prevent theft, with this system the lorry doors are only opened shortly before loading. The semi-trailer or swap trailer can remain docked to the loading bay unattended, e.g. overnight. A safe situation for drivers as well: they can dock completely without exiting the vehicle, preventing them from entering the zone between the vehicle and the ramp.

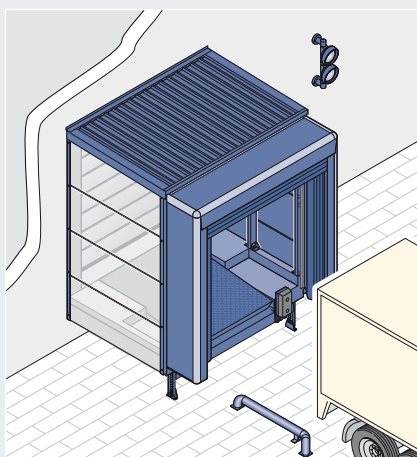

#### Recommended product

- Loading house with hydraulic telescopic lip dock leveller as DOBO version and with extended lip
- Graduated pedestal
- Industrial sectional door with low U-value
- Inflatable dock seal
- Height-adjustable buffer
- Wheel guide

### DOBO system for refrigerated warehouses and effective building use

To fully utilise the floor space of a refrigerated warehouse, the DOBO system is combined with a thermal loading house. The industrial door closes the loading house from the outside. The expanded temperature controlled area is insulated efficiently through insulated panels on the exterior walls and under the pedestals, as well as the door travelling in front of the dock leveller.

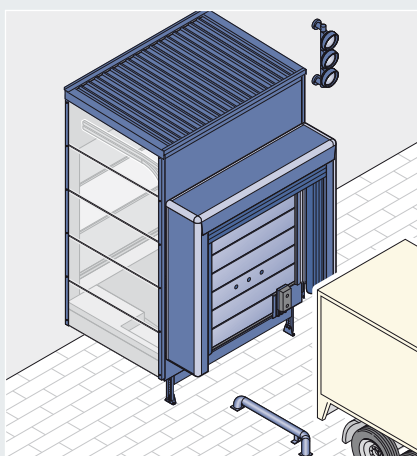

#### Recommended product

- Thermal loading house with hydraulic telescopic lip dock leveller as DOBO version with extended lip
- Graduated pedestal
- Industrial sectional door with low U-value
- High-speed doors for deep-freeze logistics
- Inflatable dock seal
- Height-adjustable buffer
- Docking assistant HDA-Pro
- Wheel guide

# Hydraulic dock levellers

Comfortable operation with great levelling



Hydraulic dock levellers are available as hinged lip or telescopic dock levellers. With a length of up to 5 metres, they can bridge large height differences between the ramp and the lorry loading level. Up to a size of 2000 × 3000 mm, the dock leveller platform is made of a single piece. With wider and longer dock levellers, a carefully made weld seam joins the plates, resulting in a continuously sturdy platform. **All Hörmann dock levellers comply with the requirements of EN 1398.**

# Detailed quality

## For long, sustainable use



### Flat transitions

The flat transitions from the platform to the telescopic lip and to the loading surface ensure safe loading.



### Stable telescopic lip

The telescopic lip with a robust front lip is reinforced throughout. The 12 / 14 mm thick running plate is made of a single piece.

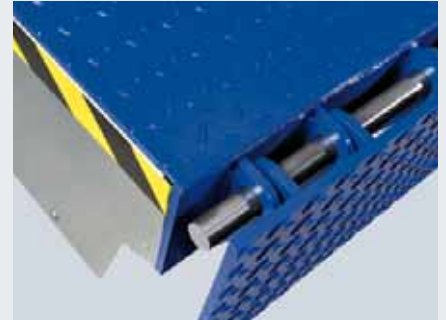

### Robust hinged lip

The open design with hinge points close to one another prevents the accumulation of dirt, such as wood shavings, in the hinge.



### Safe, reliable operation

2 hydraulic cylinders ensure the balanced, reliable and, most importantly, safe operation of the dock leveller. It comes equipped with automatic emergency-stop valves.



### Long-lasting design

A high-quality running plate, 6 / 8 or 8 / 10 mm thick, with a standard rated load of 60 kN permanently carries goods and transport equipment.



### Reinforcements on the underside

The number and design of the girders prevent deformation (track groves) beyond the degree required by EN 1398.

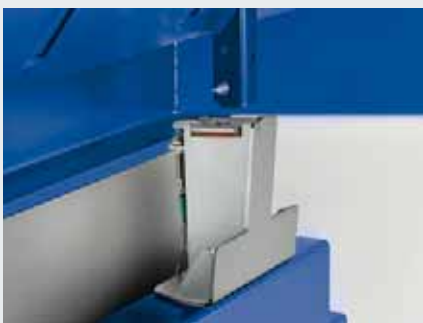

### Noise-reducing pedestal

Steel meeting steel results in a noise that is neither pleasant nor healthy for employees. Rubber buffers on the telescopic lip dock leveller pedestals reduce the contact noise when positioning the platform.

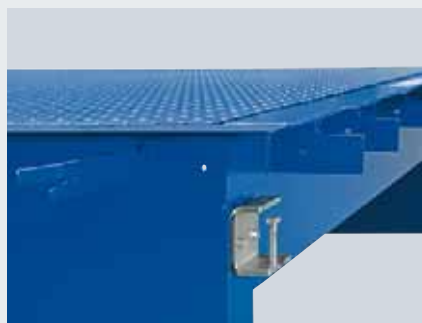

### Adjustable angle and fitting anchors

Adjustable angles to screw allow the dock leveller to be adjusted optimally. Anchor brackets on the frame that are welded before being cast to reinforcing iron or the reinforcement ensure a reliable connection. Especially in the rear area where strong forces are at work on the hinges.

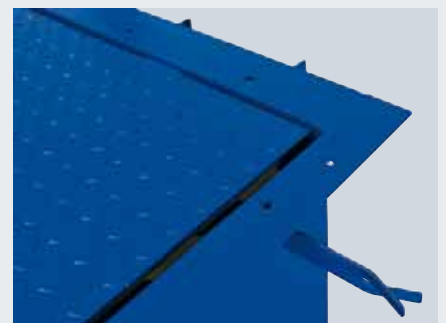

### Practical ventilation holes

Air pockets, which may above all form in the area below the edge bracket, weaken the connection of the dock leveller to the building structure. Ventilation holes in the edge bracket ensure that the air is released in the sealing process, guaranteeing a closed-linkage connection.

# Hydraulic dock levellers

Precise levelling, even with great distances from the lorry loading area

## Standard equipment

### Rated load/carrying capacity

Hörmann dock levellers have a carrying capacity of 60 kN as standard (rated load according to EN 1398). Higher rated loads, even up to 180 kN for the HLS-2, are available upon request.

### Gradient/slope

See "Determination of the levelling" on pages 30/31 (acc. to EN 1398 max. 12.5 % allowed).

### Surfaces

Moulded, slip-resistant steel, shot-blasted or anodised and coated with two-component PU varnish. Optionally also available completely galvanized, recommended for outdoor use, for example in loading houses.

### Colours

Ultra marine blue (RAL 5002) or Traffic black (RAL 9017), other colours based on RAL available upon request.

## Special equipment



### Anti-slip coating

For increased anti-slip requirements (class R11 according to DIN 51130). The anti-slip coating is applied on moulded material. This ensures that even in case of damage, the anti-slip requirements of EN 1398 continue to be complied with.



### Acoustic insulation

This additional coating on the platform and lip reduces the contact noise and thus creates a pleasant work environment.



### Gap sealing

For dock levellers that are fitted inside the building, we recommend gap sealing. When the dock leveller is not active, it seals the side gap and prevents drafts as well as the escape of warm air.

## Lip shapes

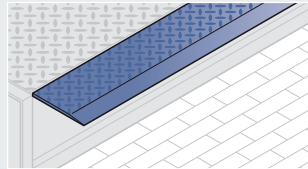

### Type R, straight

Standard up to 2000 mm ordering width

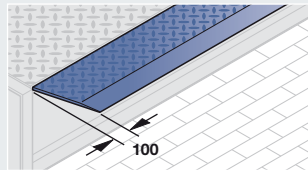

### Type S, angled

Standard over 2000 mm ordering width

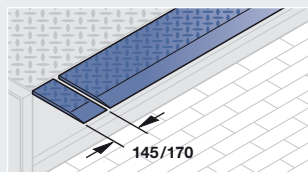

### Type SG, with separate lip segments to accommodate different lorry widths

(for telescopic lip dock levellers 170 mm wide and retractable, for hinged lip dock levellers 145 mm, the segments can be loaded with up to 1 tonne)

## Lip lengths

Select a lip length to ensure a bearing surface of 100 – 150 mm in accordance with EN 1398. Note the distance from the lorry to the ramp using buffers on the ramp and vehicle.

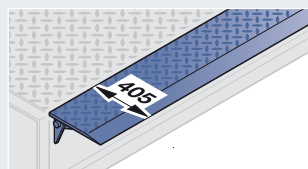

### Hinged lip dock leveller

The lip is 405 mm long as standard, 500 mm also available on request. When selecting, please note that the protruding lip hinge reduces the possible levelling. Request detailed information and seek consultation!

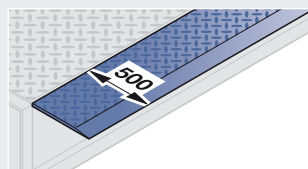
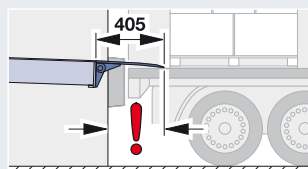

### Telescopic lip dock leveller

As standard, the telescopic lip is supplied in a length of 500 mm. Some applications, particularly when the building door is positioned in front of the dock leveller, require a longer lip. For such cases, the telescopic lip lengths 1000 mm and 1200 mm are available.

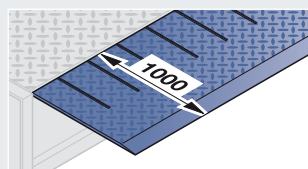

## Hinged lip dock leveller

The electronic hydraulic system moves the platform to the highest position and then automatically extends the hinged lip. The platform is then lowered until the hinged lip is placed on the loading surface. Now the lorry can be quickly and safely loaded and unloaded. Particularly strong hinges and the continuous hinge band guarantee reliable functioning. The open design keeps the hinges free of dirt.

For especially heavy goods, for example when loading paper, the hinged lip dock leveller is also available for rated loads up to 180 kN.

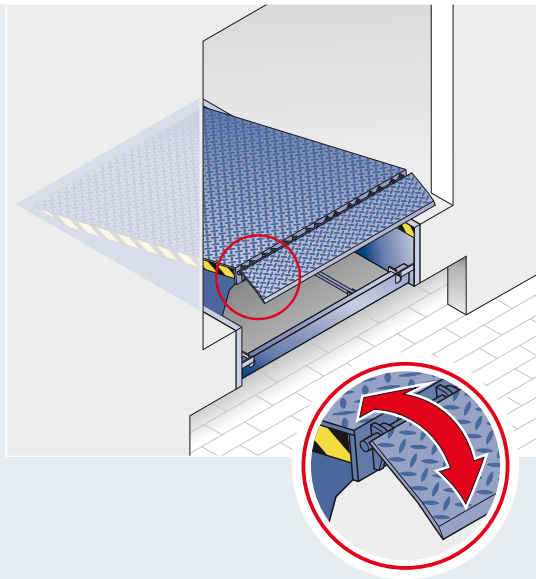

### HLS hinged lip dock leveller

As standard with a 405-mm-long lip. Rated loads up to 180 kN are available upon request.

Due to the lip hinges, the bridging length does not correspond to the lip length. Please seek consultation.

## Telescopic lip dock leveller

The continuous and to the centimetre precise extending and lowering of the dock leveller's telescopic lip allows simple and safe unloading of even fully loaded lorries. This way, even pallets that are situated at the end of the vehicle's loading surface and thus only provide limited telescopic lip space, can be loaded.

The design with interleaved beams of the platform and telescopic lip as well as side plastic runners, ensures regular and reliable guiding.

The telescopic lip can be extended and retracted in a targeted manner via separate control buttons, and can be placed precisely and controlled on the loading surface. Marks on the telescopic lip indicate the minimum and maximum positioning depth.

The telescopic lip has a length of 500 mm as standard. Longer versions are also available. These are required, for example, when the dock leveller is located behind the door construction.

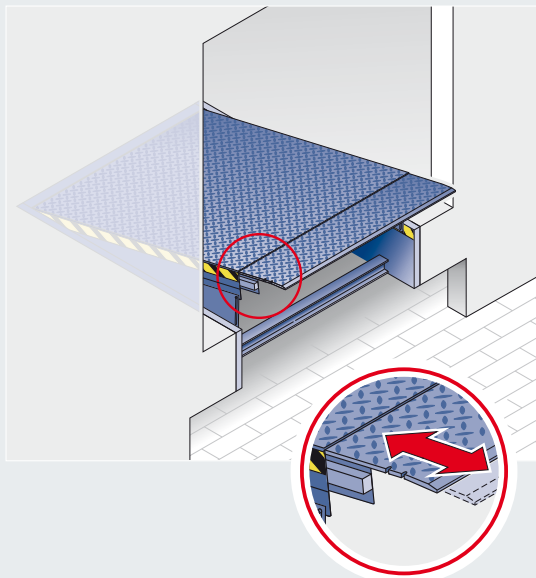

### HTL 2 telescopic lip dock leveller

Standard with 500 mm long telescopic lip.

Indentations in the dock leveller mark the optimal support surface between 100 – 150 mm.

# Dock levellers for special requirements



With telescopic lip dock leveller HTLV 3, lorries and transit vans can dock on a loading bay



The lift leveller is a combination of a telescopic lip dock leveller and scissors lift table

## Dock leveller with 3-part telescopic lip for lorries and transit vans

The advantage of the HTLV 3 dock leveller with a 3-part telescopic lip: You can load and unload lorries and delivery vans at the same ramp.

The entire width of the telescopic lip (approx. 2000 mm) can be continuously extended for lorries. With a rated load of max. 60 kN, the HTLV 3 can be used like a conventional dock leveller.

A simple switch on the control lets you extend the centre section of the telescopic lip, while the side parts remain mostly behind, making it ideal for delivery vans. An intelligent hydraulic system provides the necessary weight compensation to relieve the load on the van. The dock leveller follows the movement if the loading floor of the delivery van lowers during loading. This ensures proper positioning at every point. The dock leveller can be loaded by up to 20 kN in accordance with EN 1398.

**Not every forklift is suitable for the resulting gradient. A longer dock leveller ensures a more favourable angle. Let us advise you!**

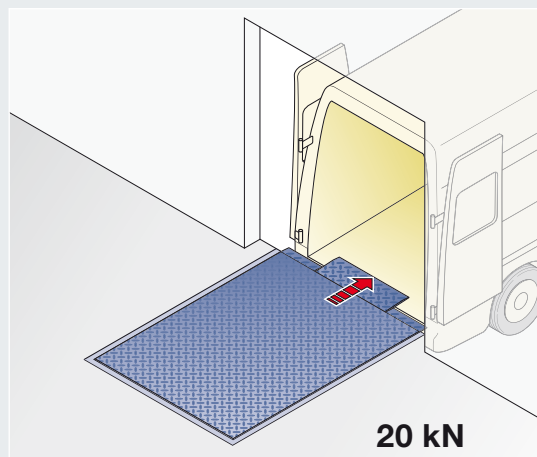
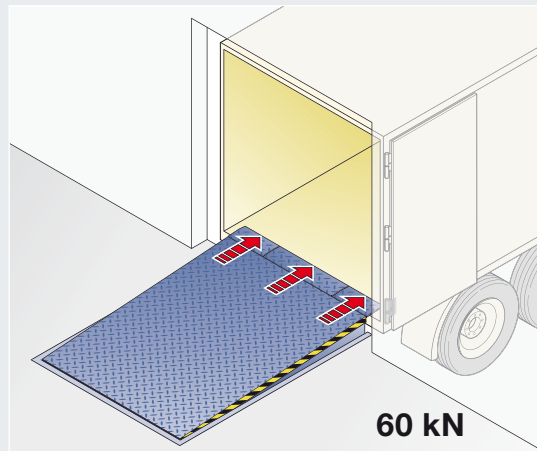

Telescopic lip dock leveller HTLV 3

## DOBO system

Dock first – open doors later



The DOBO system is the ideal solution: For hygienic transport, to warrant uninterrupted cold chains, lower energy costs, theft prevention or for customs purposes. For additional safety: the driver can safely dock without exiting the vehicle. This minimises the risk of accidents in the danger zone between the vehicle and ramp.

### Hörmann practical application tip

The DOBO system can also be implemented in conjunction with a loading house.

On conventional ramps, the driver gets out of the vehicle, opens the vehicle door and then docks the vehicle.

If the vehicle has already docked on the previous evening, inconvenient adjustment processes are necessary to open the doors.

With the DOBO system, a lorry can dock with its doors closed. They can be opened whenever needed. Until that time the goods remain well protected inside the vehicle.



Take a look at the video at:  
[www.hoermann.com/videos](http://www.hoermann.com/videos)

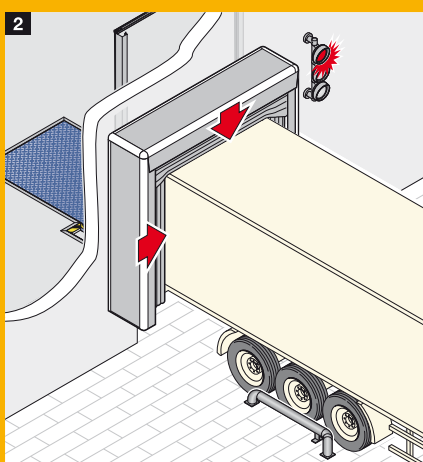
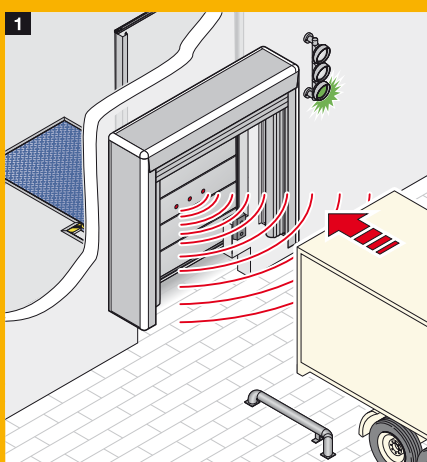

#### 1 Safe docking

The Hörmann Docking Assistant HDA helps the driver to dock safely. The vehicle doors remain closed. Sensors in the door leaf recognise the position of the vehicle.

#### 2 Reliable sealing

As soon as the lorry is docked, the dock seal DAS-3 is inflated and seals the vehicle from 3 sides.

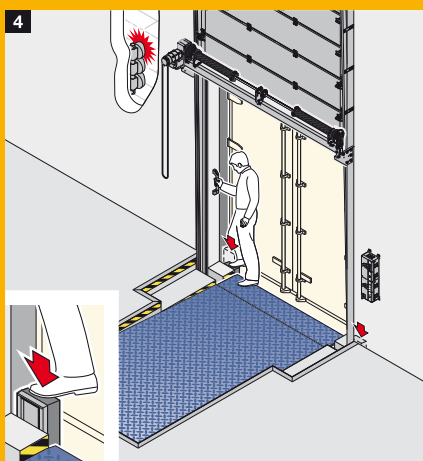
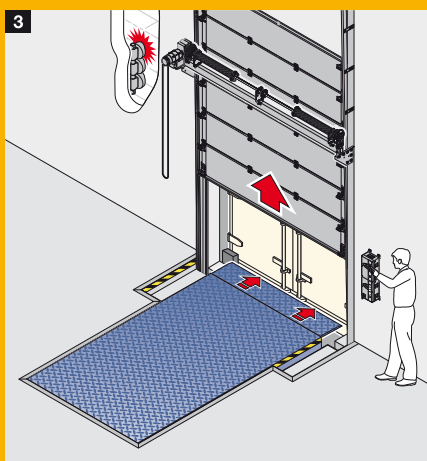

#### 3 Opening the dock door

After the door is completely opened, the telescopic lip of the dock leveller is extended to decrease the gap to the vehicle.

#### 4 Lowering the bumpers

Now the flexible bumpers VBV 4 can be lowered manually and locked to open the lorry doors.

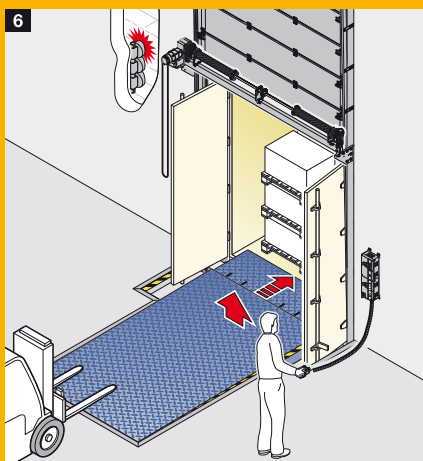
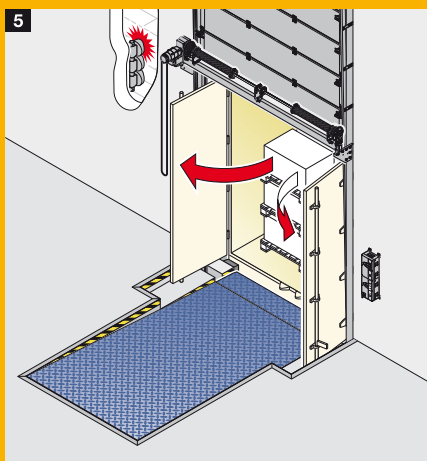

#### 5 Opening the vehicle door

The ramp features a recess that provides enough space for the door to open completely.

#### 6 Extending the dock leveller

The dock leveller HTL 2 with a 1000 mm long telescopic lip easily bridges the gap between the ramp and the loading floor and can be precisely positioned up to the last centimetre.

# Control systems

## Compatible system solutions



From development to production, all Hörmann products come from the same source, making them optimally matched to each other.

You benefit from a uniform operating concept with standardised housing sizes and similar cable sets for all dock levellers and door controls.

Another advantage: If the dock leveller control is placed beneath the door control, both controls can be combined into a single compact unit.

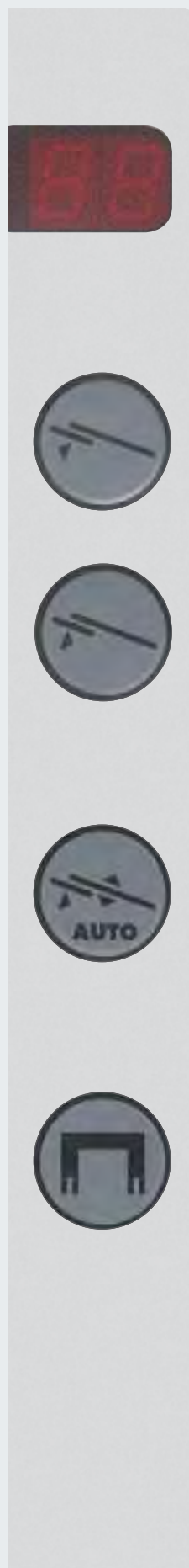

### Comfort function for simple operation

#### Double 7-segment display with operational and error display

- for comfortable menu readout and programming
- Service menu with maintenance, cycle, and operating hours counter, as well as fault analysis
- Readout of the last 5 error messages

#### Comfort telescopic lip operation

Two separate buttons for the extension and retraction of the telescopic lip allow comfortable and precise positioning on the loading surface.

#### Automatic impulse re-parking with telescopic lip and hinged lip dock levellers

With a single impulse the dock leveller is completely returned to its normal position. This function is standard for all controls. With the respective equipment the door subsequently closes automatically.

#### Integrated control of the dock seal

The operation of an inflatable dock seal or an electric top flap can be integrated into the dock leveller control.

#### Semi operation sequence control

The door opens automatically as soon as the dock seal has been inflated or the electric top flap has been lowered. As soon as the dock leveller is returned to the normal position, the door closes automatically and the dock seal switches off or the top flap extends.

The energy saving mode for controls 420 S / T and 460 S / T lowers electricity costs by approx. 80 %



	Hinged lip dock levellers		Telescopic lip dock levellers	
	Basic control	Multiple controls	Basic control	Multiple controls
Control	420 S	460 S	420 T	460 T
Control in protection category IP 65 (jet-water protected)	●	●	●	●
LED operation indicator	●		●	
7-segment display with operational and error display		●		●
Prepared for the connection of wheel chock with sensor	●	●	●	●
Prepared for the dock leveller release function	●	●	●	●
Prepared for the door release function	○	●	○	●
Comfort telescopic lip operation			●	●
Automatic impulse re-parking	●	●	●	●
Integrated control button for dock seal		●		●
Automatic door close function		○		○
Semi operation		●		●
Expanded connection options		●		●
Energy saving mode	●	●	●	●

● as standard  
○ with corresponding equipment



Control WA 300 (above) in combination with control 420 S (below)

### Push button control 300 U

- For the operation of Hörmann industrial doors with operator WA 300
- Compact unit in combination with dock leveller controls 420 S and 420 T
- Optionally available with an integrated main switch
- Space-saving and inexpensive solution

### External control DTH-T

Allows for the exact control of the dock leveller at the loading point. For further information, please see page 56.



### Dock management

#### Visualisation ensures controlled processes

You control, monitor and manage the entire control system via a graphic interface. It is depicted via a control panel or a web application.



# Safe start-up and docking

## Docking assistants



Safe and comfortable start-up. With the Hörmann Docking Assistant **HDA-Pro** and **HIB-Pro**.

The Hörmann docking assistants HDA-Pro and HIB-Pro make driving up to the loading bay comfortable and safe. While manoeuvring, the colour of the warning light tells the lorry driver how far he is from the dock. Red indicates that the optimal docking position has been reached and the lorry should be stopped.

### HDA-Pro Docking Assistant with sensors in the door leaf

Several sensors on the door leaf register the rear side of the closed lorry and control a “green-yellow-red” signal system.

The precise measurement takes place via ultrasound waves. The distance and position of the individual signal phases up to a distance of 3 m and can be simply programmed with the HDA-Pro control.

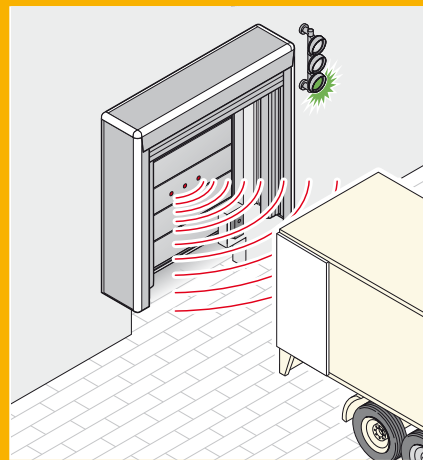

**HDA-Pro docking assistant with sensor in the door leaf**

### HIB-Pro Docking Assistant with distance measurement in the buffer

The distance between the lorry and the loading bay is recognised by the buffer. The traffic light phases can be set up to a distance of 20 cm.

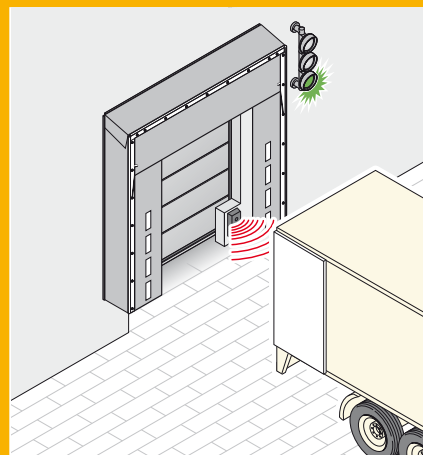

**Only from Hörmann**

**HIB-Pro docking assistant  
Distance measurement in the buffer**

# Docking support and position monitoring

## Hörmann Dock Control

Hörmann Dock Control reliably monitors and controls the entire loading process. Working as the control centre for comprehensive safety equipment, Dock Control evaluates information coming from e.g. the sensors in the wheel chock and the buffer and then controls specified blocking and signal functions.

The equipment can be adjusted depending on the customer's wishes and needs. Let us advise you!



Take a look at the video at: [www.hoermann.com/videos](http://www.hoermann.com/videos)

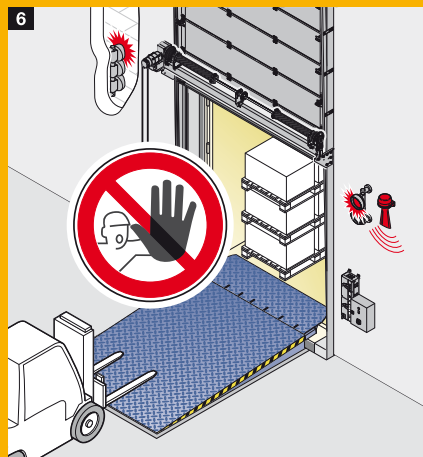
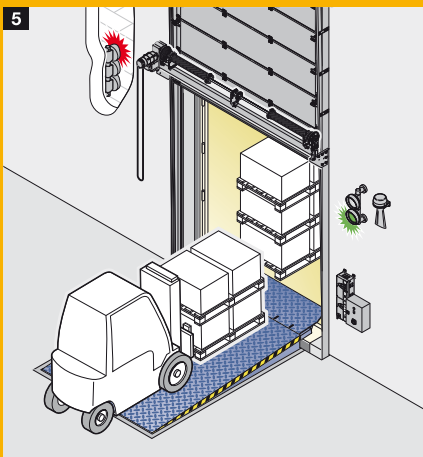
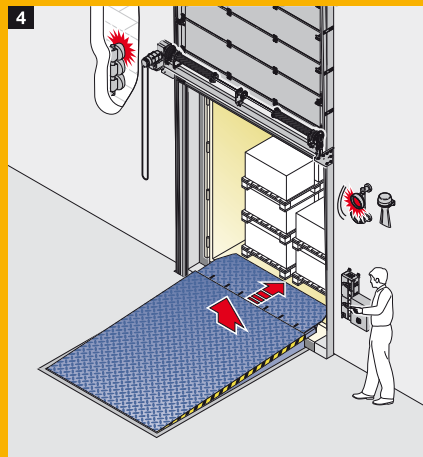
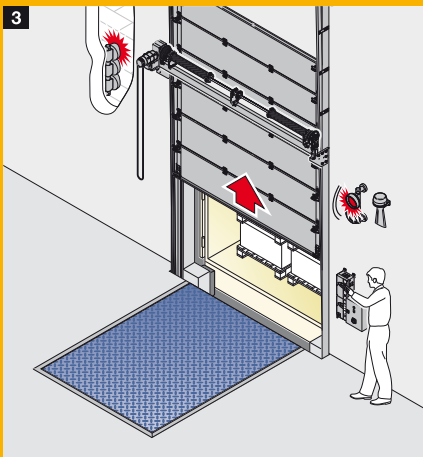
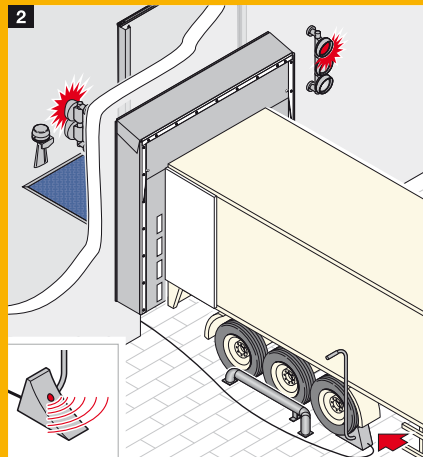
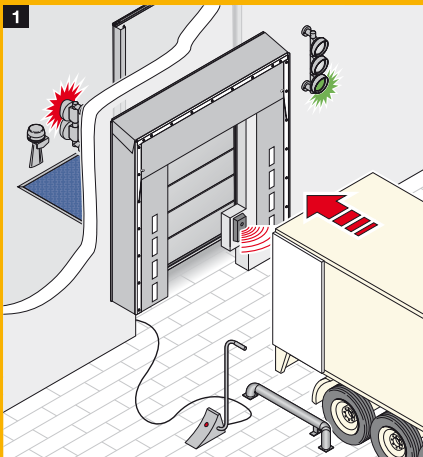

### 1 2 Safe docking

The buffer with sensor safely guides the lorry to the loading bay via the traffic light control. The sensor system in the buffer reports the distance of the lorry to the loading platform and when it has reached the final docking position. The lorry is then additionally secured by a wheel chock with a sensor. Upon contact with the tyres and the correct position, the sensor releases the door control.

### 3 4 Secured and controlled processes

After the lorry has been secured, the door can be operated. If the door is opened completely, the dock leveller is released via the door control limit switch reporting and can be operated. The traffic light then switches from red to green, releasing the loading bay. After the loading process, a sensor in the dock leveller releases the door for closing as soon as the dock leveller has returned to the home position.

### 5 6 Safety risk warning

Sensors in the buffer and the wheel chock immediately report unintended rolling away of the lorry from the ramp or the removal of the wheel chock. The traffic light inside switches to red and an acoustic warning is sounded to timely interrupt the loading process.

# Working ranges, dimensions

## Hydraulic dock leveller with hinged lip

The values in the table indicate the maximum bridgeable height difference which is permissible, taking into account the maximum gradient/tilt of 12.5 % as per EN 1398.

Note that these are limit values. The levelling required should not be in the limit value range. Instead, select the next highest length.

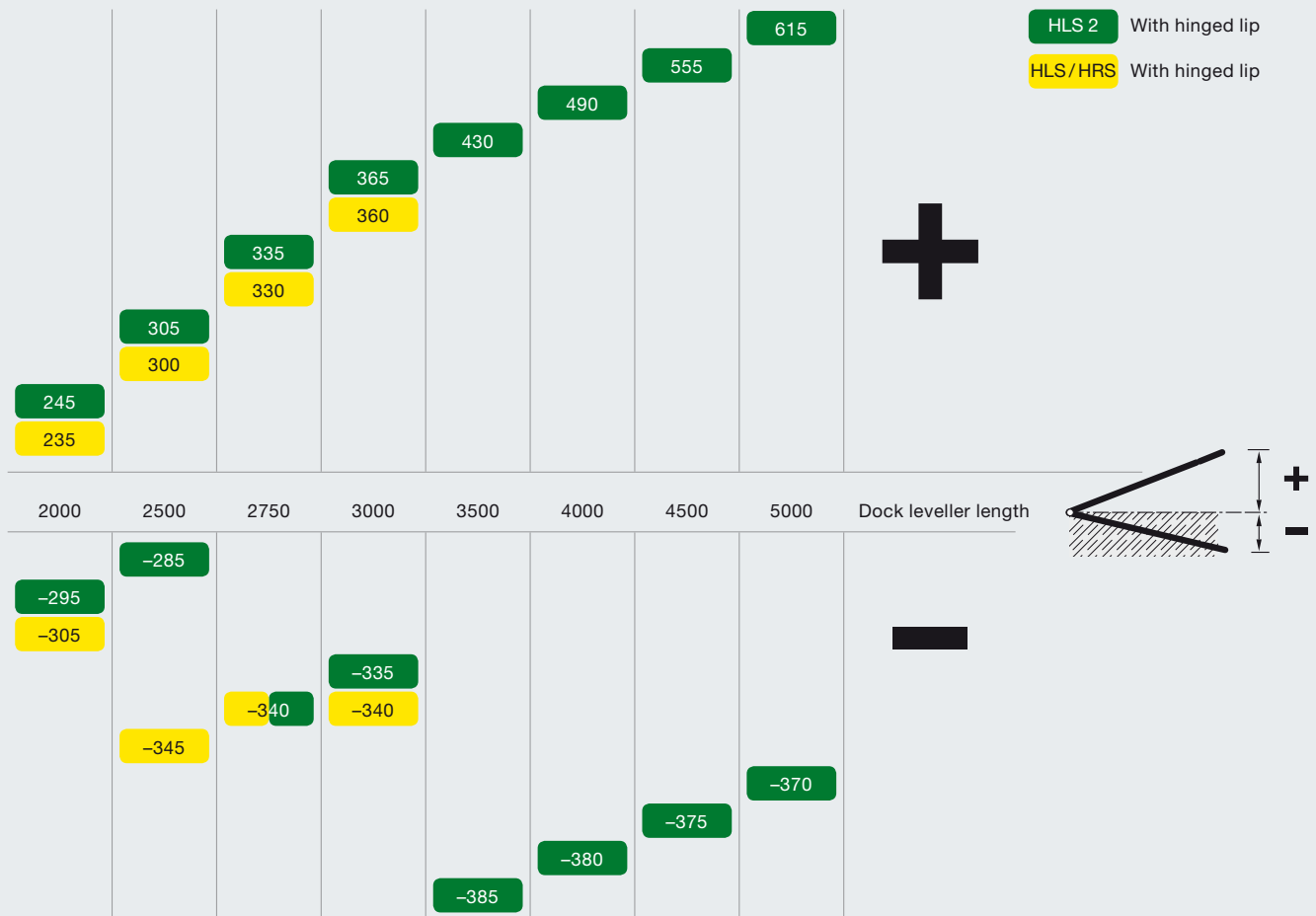

All dimensions in mm

## Dimensions

Ordering length	2000 2500 2750 3000 3500 4000 4500 5000									Ordering width
Dock leveller										Dock leveller
Installation height	HLS	650	650	650	650					2000, 2100, 2250
	HLS2	595	595	645	645	745	745	745	745	
Possible ramp height	HRS	910 – 1350								2000, 2100, 2250 overall width 3500 mm

All dimensions in mm



### Hörmann practical application tip

Adjust the ramp height to the most frequently used lorry height. This ensures quick loading and unloading processes as well as less stress on the dock leveller.

## Hydraulic dock levellers with telescopic lip

The table indicates the maximum working range (limit value range) when the lip is extended completely. Various factors play a role in determining the optimal dock leveller length.

Request our documents or seek consultation!

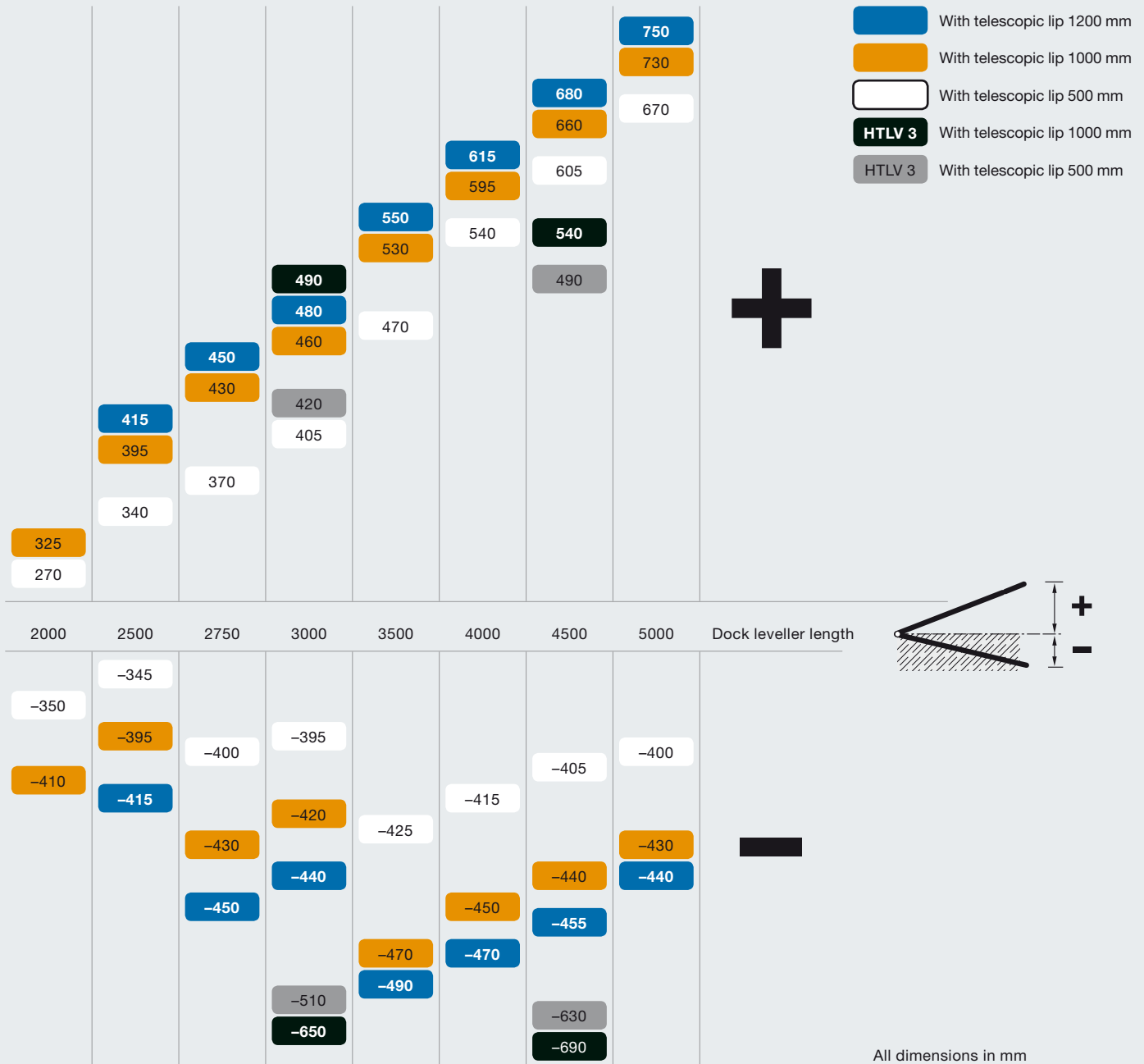

All dimensions in mm

### Dimensions

Ordering length Dock leveller		2000	2500	2750	3000	3500	4000	4500	5000	Ordering width Dock leveller
Installation height	HTL2	595	595	645	645	745	745	745	745	2000, 2100, 2250
	HTLV 3				795			895		2000
Possible ramp height	HRT	1050 – 1425								2000, 2100, 2250 overall width 3500 mm

All dimensions in mm