

SMOOTHER

High-speed Roll-up Door









Highly Air-Tightened × Wind resistance × Eco = **SMOOTHER**



More environmentally and user friendly.
SMOOTHER satisfies customer needs.

I N D E X

Seven Distinctive Features	—————	P.3	
Specifications and Options	—————	P.6	
Highly Air-Tightened Model for Indoor Use	— RA-1AT <small>New model</small> —	P.9	
Compact Model for Indoor Use	— RA-1C —	P.9	
Model for both Indoor and Outdoor Use	— RB-2, RB-3 —	P.11	
Large-sized Model for both Indoor and Outdoor Use	— RB-4 <small>New model</small> —	P.13	
Model for Refrigerating Room	— RA-1R —	P.15	
Explosion-Proof Model	— RS-2E —	P.17	

Seven Distinctive Features



Achieved A-3*, the industry's highest level of air tightness

Although the newly designed RA-1AT is a pipe model, it offers excellent air tightness equivalent to **A-3 class** (the industry's highest level) as defined in the Japanese Industrial Standards. An airtight gasket allows the RA-1AT to provide about 10 times of the air tightness of our standard RA-1C model. It also provides high insect/dust-proof performance to keep the work environment clean.

*A-3 class is:

A level of air tightness performance defined in JIS A 1516 to indicate how much air leaks from the shutter frame or gap. The RA-1AT meets an air leak level of $8 \text{ m}^3/\text{h}\cdot\text{m}^2$ or less at 10 Pa of pressure difference.

	Air leak volume at 10 Pa ($\text{m}^3/\text{h}\cdot\text{m}^2$)	
	RA-1AT	RB-2 optional high air-tightened type
Positive pressure	7.6	19.2
Negative pressure	6	18.7

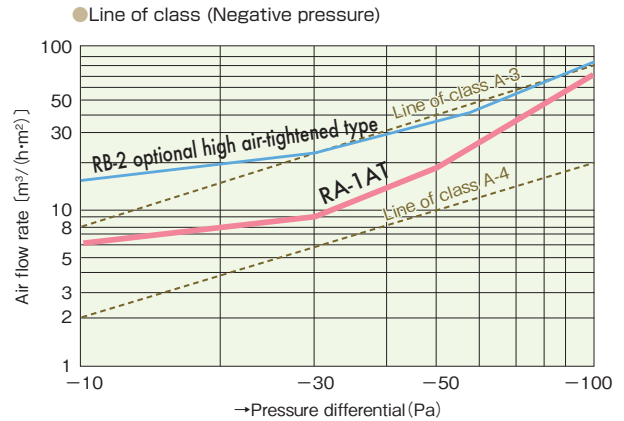
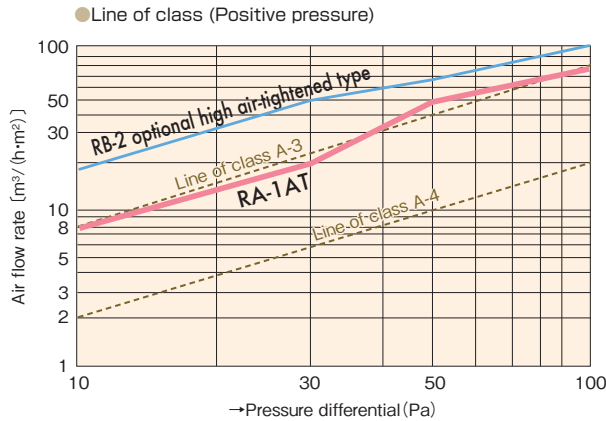

*The values indicated here are test results, not guaranteed values. *The RB-2 highly air-tightened type is optional. * As of November 2009.



29.3 m/s* of wind pressure resistance when fully closed. The industry's highest level of wind pressure resistance enables smooth opening and closing.

*Converted value (to wind speed), calculated based on the RB-4 with an effective opening width of 6,050 mm.

SMOOTHER easily opens and closes without a steel shutter even in strong winds thanks to bearings (rollers) on the pipe ends. Achieves the industry's highest level of wind pressure resistance among ultra-large shutters.

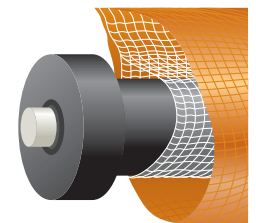

▲Bearings on the pipe end of the sheet (RB-4)

●Wind pressure-resistant performance(Wind pressure at with the pipe yields or comes off the rail when stopping at the lowermost level)

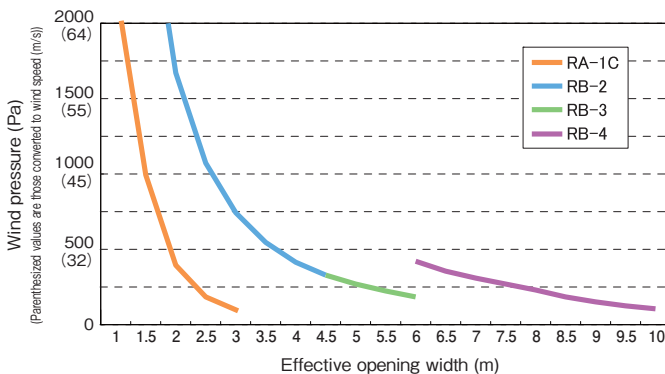

●Wind velocity resistant performance(When in operation: wind velocity at which the sheet can descend)

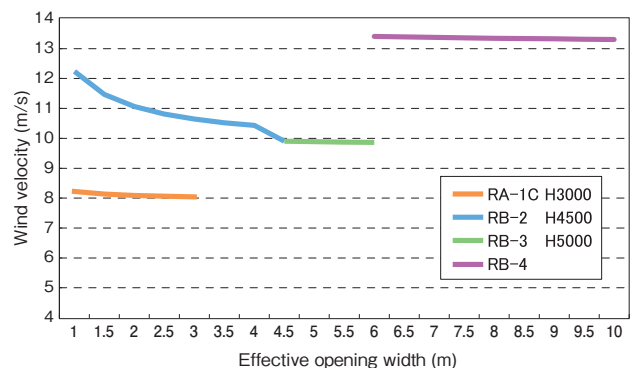

*This performance data is not a guaranteed value in any way. Be careful because it varies depending on the wind direction, use environment, etc.

Explosion proof

Sheet shutter complying with JNIOOSH Explosion-Proof Guidelines.

Available for up to Zone 2* (formerly class 2 area).

SMOOTHER "RS-2E" is applicable to chemical or other plants and facilities where hazardous substances are processed. This model adopts both a pressure-resistant, explosion-proof construction and an intrinsically safe construction, instead of a structure simply offering a higher degree of safety. The RS-2E never becomes a source of fire, thereby ensuring user safety.

* Zone 2 is:

An area where an explosive atmosphere is unlikely to develop during the normal operation of plants or similar facilities, or where such an atmosphere may develop only for a short time even during abnormal operation (excerpt from JNIOOSH Explosion-Proof Guidelines for Plants' Electric Equipment).

Electric equipment used in such a hazardous area must be of an approved model type.



(RS-2E)



▲Pressure-resistant, explosion-proof type electrical motor

Large opening

The largest size in the industry for ultrawide opening. <RB-4>

The largest size in the industry, enabling up to 60 m² of indoor/ outdoor opening (10 m in width and 6 m in height).

Allows large vehicles such as trucks or forklifts carrying large materials to pass smoothly. Safety sensors (rail embedded type, two optical axes) are also equipped as standard to ensure even higher safety. Users can easily adjust these sensors.

<Conventional size>

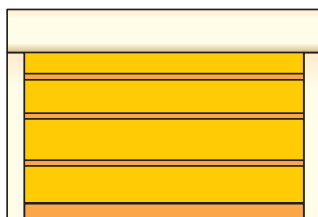

<Smothers RB-4>

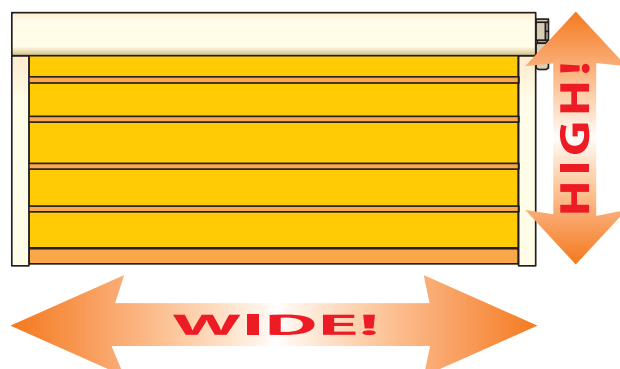

Backup power

Embedded backup power available. The only feature of its kind offered in the industry. Ensures operation during an emergency. (*Optional for the RA-1C)

The sheet opens and closes by using the embedded backup power in case of power failure due to an earthquake or fire. If emergency evacuation is needed during a power failure, the backup power prevents such situations as closed sheet blocking an evacuation route with someone left inside, as is the case with conventional products.

[One of three types of operation can be selected in case of power failure.]

1. **Manual operation:** Users manually operate the ascend/descend buttons on the operation panel to open and close the sheet (up to two times).
2. **Automatic operation:** Detects the stop due to a power failure and automatically opens the sheet.
3. **External signals:** When certain external signals are received, the sheet fully opens.

Backup power supply	Power outage compensation	Frequency of sheet operation 2 times (in 30 minutes during standby time)
	Output voltage	Nominal DC 72 V
	Battery service life	Recommended replacement every three years
	Type of power supply	Nickel-cadmium battery
	Charging time	48 hours (charging time required after discharging to below 50% of battery content capacity)

Safety

Equipped with a “Flap function” that allows the pipe to easily disengage when something comes into contact with the sheet, thereby preventing possible rail and sheet damage.

- The RA series is equipped with the “Flap function” (optional for the RB-2) as standard. This allows the pipe to easily disengage, thereby preventing possible rail and sheet damage, even if a forklift comes into contact with the sheet.
- The lower pipe of the sheet is enclosed in cushion material to reduce shock impact.

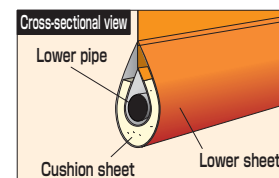
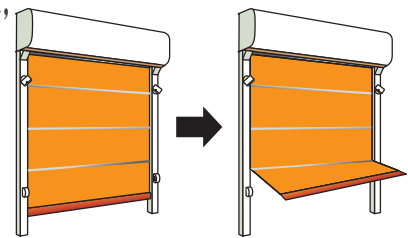

*The figure shows the RA series.

ECO

Minimizes airflow through speedy open/close operation and by adjusting the opening height to accommodate passing objects.

- **High-speed open/close operation** (sheet opening speed: 1.2 m/s) increases work efficiency and minimizes the entry of insects and dust.
- For example, to allow the entry of people, press the push button set to open the shutter to height ①. Entering vehicles will be detected by the infrared sensor set to open the shutter to height ②. This setting minimizes air-conditioning loss, thereby contributing to energy saving.

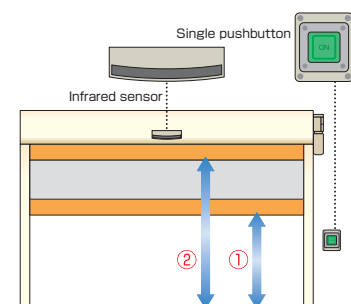

● Specifications

		RA-1AT,RA-1C	RB-2	RB-3	RB-4	RA-1R	RS-2E
Effective opening regulation	Effective opening width (mm)	W800~3000	W1000~4500	W4550~6000	W6050~10000	W900~3000	W1000~4000
	Effective opening height (mm)	H900~3000	H1000~5000		H2000~6000	H900~3000	H1000~4000
Components used	Box	Colored steel plate				Stainless steel (control panel portion with ABS plastic cover)	Colored steel plate
	Rail	Colored steel plate				Stainless steel	Colored steel plate
	Rotor pipe	Aluminum alloyφ150	Aluminum alloyφ216			Aluminum alloyφ150	Aluminum alloyφ216
	Sheet	Polyester yarn encapsulated vinyl sheet				Polyester yarn encapsulated vinyl sheet	Antistatic sheet
	Middle pipe	φ19.1	φ38.1		φ50.8 With rollers on both ends	φ19.1	φ38.1
	Lower pipe	φ38.1			φ50.8 With rollers on both ends	φ38.1	
Operation method	Drive	DC motor (300 W)	Induction motor (output 750 W)		Induction motor (output 1.5Kw)	DC motor (300 W)	Explosion-proof motor with reduction gears and brakes (d2G4) 400 W
	Sheet speed	1.2m/s (Ascent velocity of the sheet) · 0.8m/s (Descent velocity of the sheet)	1.2m/s (Ascent velocity of the sheet) · 0.5m/s (Descent velocity of the sheet)	0.8m/s (Ascent velocity of the sheet) · 0.5m/s (Descent velocity of the sheet)	0.6m/s (6m<W≤8m) (Ascent velocity of the sheet) · 0.5m/s (8m<W≤10m) · 0.4m/s (Descent velocity of the sheet)	1.2m/s (Ascent velocity of the sheet) · 0.8m/s (Descent velocity of the sheet)	0.75m/s (Ascent velocity of the sheet) · 0.6m/s (Descent velocity of the sheet)
	Upper/lower limits setting method	Upper/lower limit switches and teaching control	Encoder control			Upper/lower limit switches and teaching control	Upper/lower limit switches
	Opening/closing speed control	Slow start/slow stop control				Slow start/slow stop control	
Sensor	Phototube sensor	Photoelectric tube sensors (reflection type)	Photoelectric tube sensors (reflection type /2 optical axes)		Photoelectric tube sensor (phototransmitting / photoreceiving type, 2 optical axes)	Photoelectric tube sensor (phototransmitting / photoreceiving type)	Explosion-proof type phototube sensor (reflection type)
Power supply	Single phase AC 100 V, (50 Hz/60 Hz) 6A	Three-phase AC 200 V ± 10% (50 Hz/60 Hz) 6 A				Single phase AC 200 V (50 Hz/60 Hz) below 700 W 8 A	Three-phase AC 200 V ± 10% (50 Hz/60 Hz) 5 A
	Single phase AC 200 V, (50 Hz/60 Hz) 3A						
Allowable frequency	120 times/h, 2 times/min	120 times/h, 2 times/min	90 times/h, 1.5 times/min	60 times/h		120 times/h, 2 times/min	
Ambient temperature	5 to 40 degree	-10 to 40 degree				-5 to 30 degree	5 to 40 degree
Environmental conditions	There should be no freezing or condensation at 20% to 90%.				Special control prevents condensation/freezing *Excluding sheet portion	There should be no freezing or condensation at 20% to 85%.	
Product warranty	There should be no toxic gas, powder dust, and condensation.				There shall be no toxic gas, powder dust, and condensation.	There should be no toxic gas, powder dust, and condensation.	

● Table of effective opening width and height by model

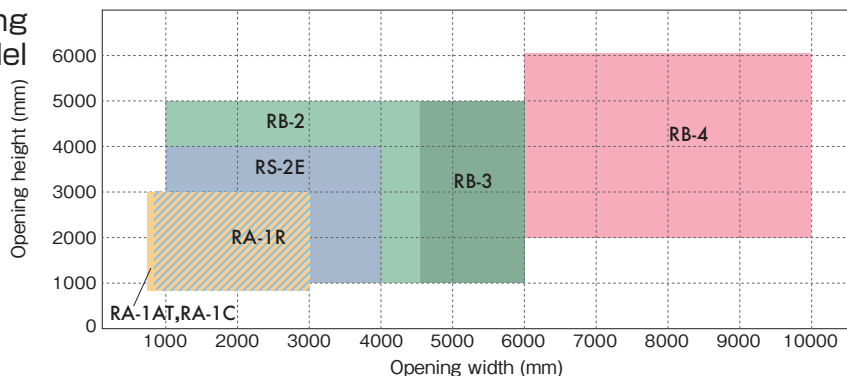

HACCP compatible option

In addition to an insect-proof orange sheet that prevents insects from coming inside, a high performance airtight gasket (optional) enhances protection against the entry of insects and dust.

Moreover, mounting a trapezoid cover on the main body or control panel prevents dust from accumulating, thereby affording easy cleaning.

Rails and a main body box made of stainless steel are also available.



▲Example of use



▲Example of use:
Trapezoid cover for main body box



▲Example of use:
Trapezoid cover for control box

Interlocking functions

Two units of Smoothers make a front chamber, which are coordinated via a microprocessor. An interlocking operation in which one side opens and the other side does not is possible. As it prevents external air from entering, it can enhance air-conditioning efficiency. An optional printed board can be added for linked operation with belt conveyors, AGVs or other equipment.

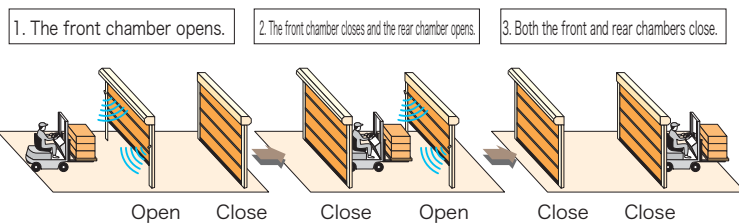

Sheet

<Standard finish>
(RA-1 series, RB-2, RB-3)

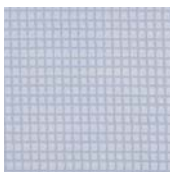

Transparent sheet
(Flameproof finish : Fire Office Registration No. E-13-42766)

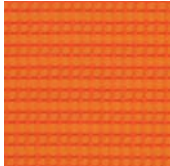

Insect-proof orange sheet
(Flameproof finish : Fire Office Registration No. E-13-42766)

<Explosion-proof finish>
(RS-2E)

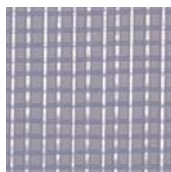

Transparent sheet
(Antistatic/flameproof finish : Fire Office Registration No. E-13-42766)

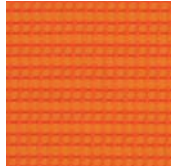

Insect-proof orange sheet
(Antistatic/flameproof finish : Fire Office Registration No. E-13-42766)

<Option>

● Antibacterial sheet (Transparent)

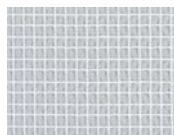

*In addition, we can supply orange color.

● Unburnable sheet

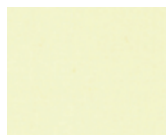

● Special mesh window material

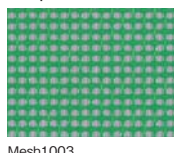

Mesh1003

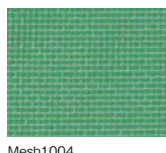

Mesh1004

Inspect-proof effect

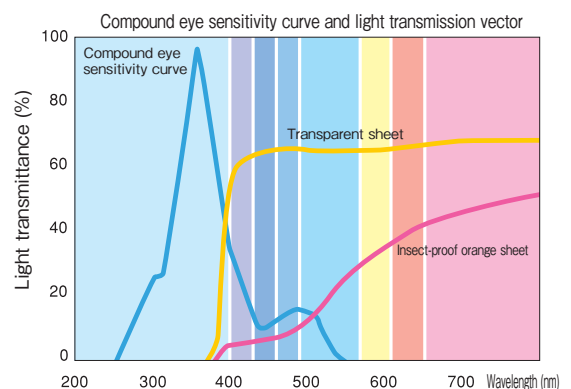

Cutting a wavelength zone of around 350 nm, to which insects are most responsive, this prevents insects from coming inside.

Sheet window

A window on the sheet allows workers to check forklift or pedestrian traffic on the opposite side to avoid collisions.

*Two types of windows (transparent or insect-proof orange color) are available.

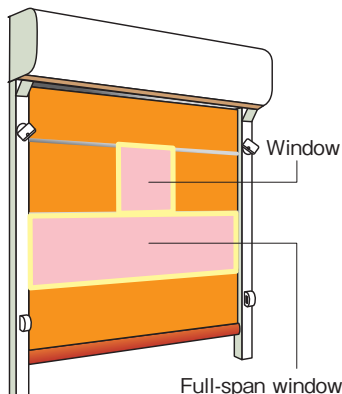

Dimension suitable for mounting windows

	Window			Full-span window	
	Maximum width	Minimum width	Height	Width	Height
RA-1AT	W-500	500	400	W+110	Maximum height set for each span
RA-1C				W+140	
RA-1R					
RB-2					
RB-3	W-800	—	—	—	—
RB-4					
RS-2E	—	—	—	—	—

* Windows that can be mounted are 1 to 3 windows for a single span or a full-span window. (The number of windows varies depending on the width of a sheet.)

* Window mounting positions may be located on the first, second, third, and fourth stages.

* Mesh window does not comply with a full-span window.

* For RA-1AT and RA-1C, if the opening width is less than 900, the maximum width of window is W-300.

For the partitions around electrical equipment in a chemical factory, this model conforms to the explosion-proof guidelines and can be used in areas up to Zone 2.

RS-2E

Only Japan Uniflow applies intrinsically explosion-proof specifications based on JNIOOSH Explosion-Proof Guidelines, instead of simply a construction to enhance safety.

Never becomes a source of fire, thereby ensuring user safety.



*Motor cover is option.

- Sheet and plastic guides undergo antistatic treatment.
- Uses a pressure-resistant explosion-proof type motor. Also optionally available are an explosion-proof type push-button, a pull switch, and a startup sensor.



▲Pressure-resistant, explosion-proof type electrical motor

RS-2E, explosion-proof model for Indoor Use

CAD download ► <http://www.uniflow.co.jp>

- Range of possible opening / Effective opening width (mm) : minimum W 1000 to maximum W 4000
Effective opening height (mm) : minimum H 1000 to maximum H 4000
- Power / Single phase AC 200 V (50 Hz/60 Hz) 5 A
- Sheet speed / 0.75 m/s when ascending / 0.6 m/s when descending

RS-2E Installation

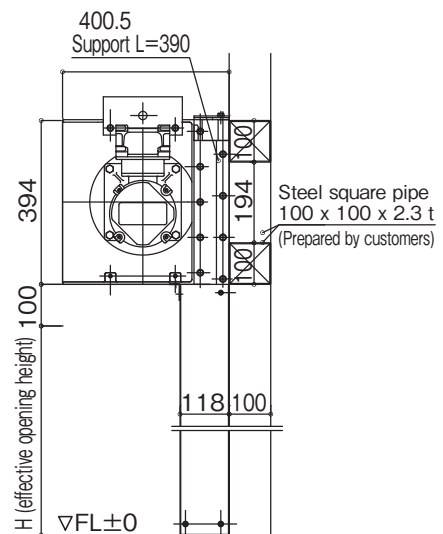
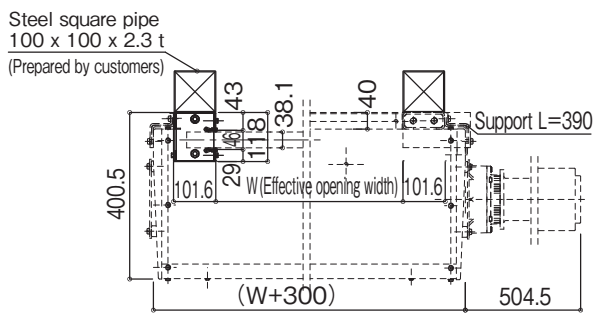
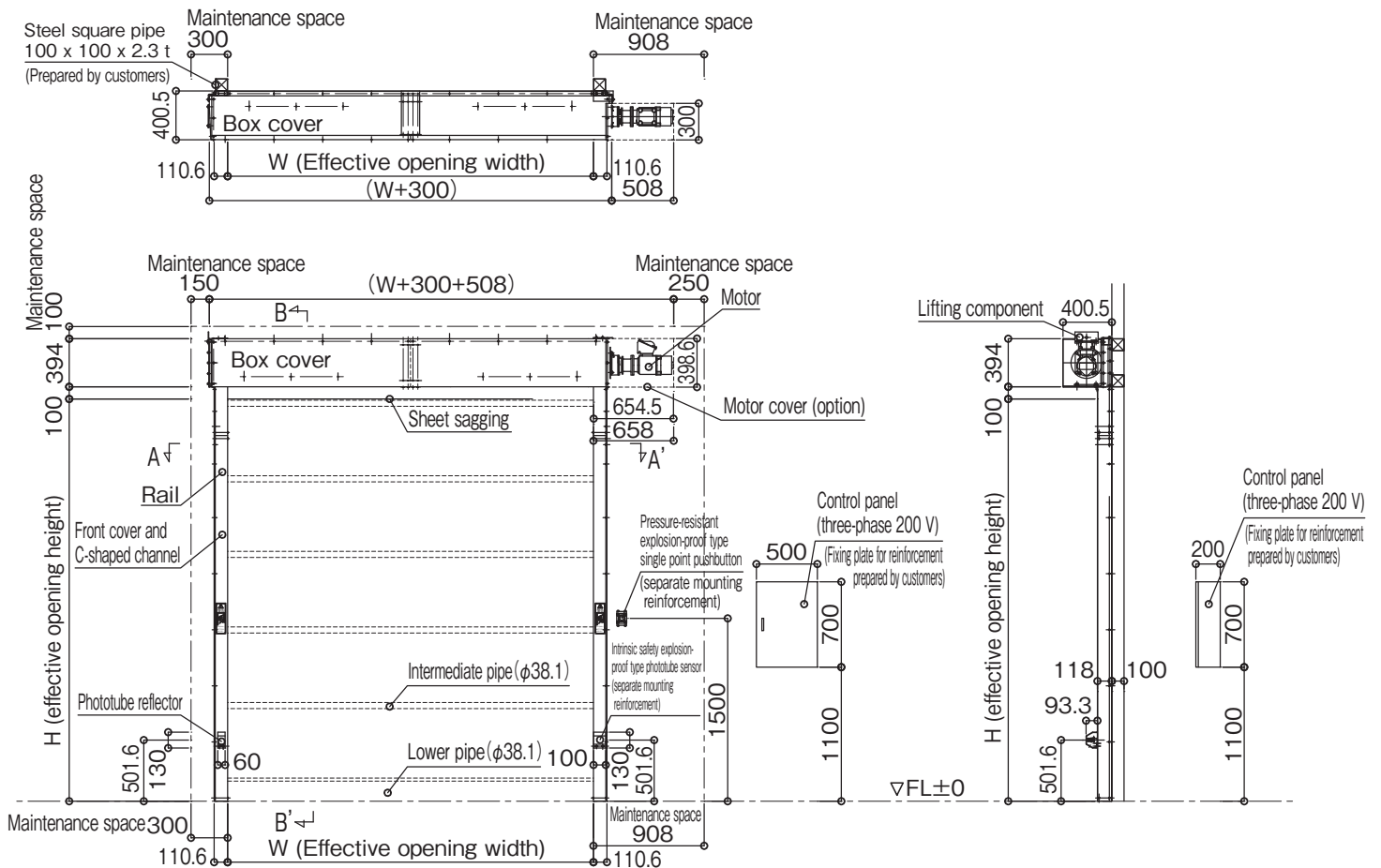

- * Install the control panel in a non-explosion-proof area.
- * Where to install the control panel or optional equipment must be determined through consultation at each site.
- * Treatment of the installation base must be determined through consultation at each site.
- * Wiring work for such optional equipment as explosion-proof primary cables and switches is not included. The customer must make arrangements with electric construction suppliers to perform such work.
- * The drawings above show the motor set in right side (standard type).